

# Accord<sup>®</sup> Panel Clip

## Attachment Fixture for Partitions, Panels & Screens

PC-E

## Installation Information

### Panels from 1-1/8" to 1-11/16" Thick

1. Place Part B over back of partition/panel (long leg down, short leg on top). See Illustration 1.
2. Peel Double-Sided Tape backing off underside of Part A.
3. Place Part A over front of partition/panel, align left to right and slide down onto top of Part B. See Illustration 1.  
*NOTE: Apply pressure to tape line to insure adhesion.*
4. Remove Panel Clip from partition/panel. Slide SignBand flange into Panel Clip Slot (see illustration 2).
5. Snap End Caps into SignBand Profile
6. Hang Panel Clip with SignBand over partition/panel.

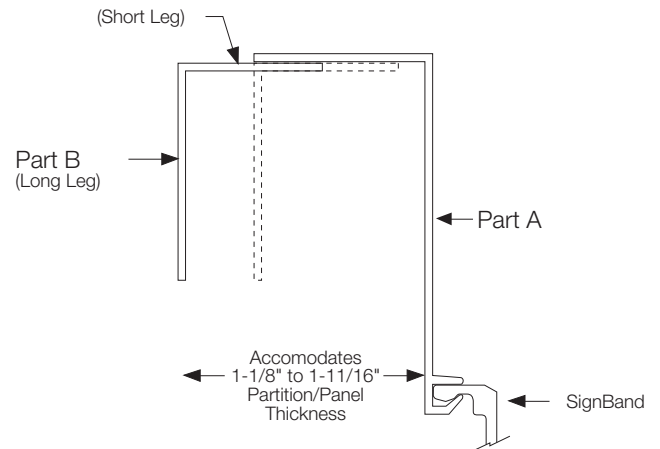

### Panels from 1-11/16" to 2-3/16" Thick

1. Place Part B over back of partition/panel (short leg down, long leg on top).
- 2.-6. Follow above instructions.

*NOTE: Once Panel Clip is assembled, it cannot be used on a partition/panel of greater thickness and may not function properly on a partition/panel of lesser thickness.*

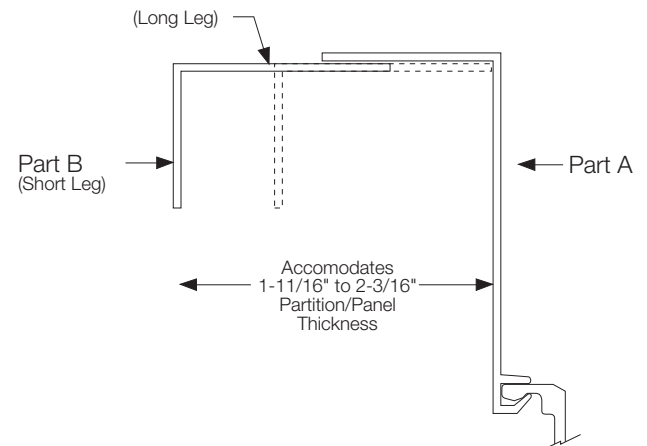

### Illustration 1

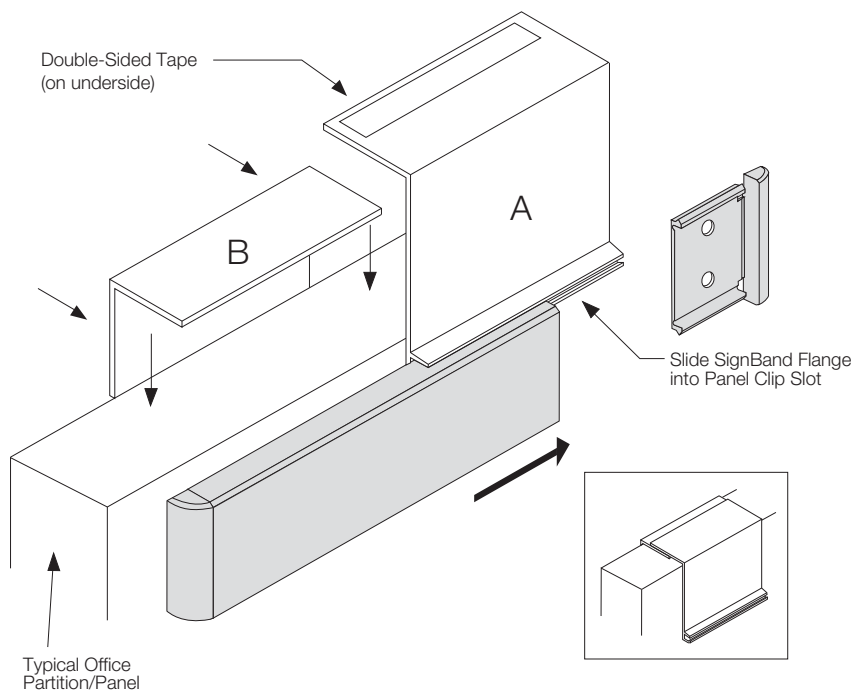

### Illustration 2

