

Visuline® 2300.1GC Series

Semi-Recessed Display



SUBMITTED FOR APPROVAL

This product is scheduled for shipment the week of :

Date _____

Production cannot begin until one (1) copy of these drawings is returned with your signature of approval by :

Date _____, otherwise rescheduling will be necessary. Drawing revisions may also require rescheduling.

Retain _____ Set(s)

Return _____ Set(s)

Customer Approval Required *(Check appropriate box)*

Purchaser _____

By (Print name & title clearly) _____

Signature _____ Date _____

Approved for Production

Approved as noted

Not approved
Resubmit with changes
Product subject to rescheduling

FOR REFERENCE ONLY *(Customer Waives Approval)*

Production Has Begun

This product is scheduled for shipment the week of :

Date _____

It is understood that customer, in waiving formal approval procedure, assumes full responsibility for the specifications, dimensions and details included herein.

APCO Use

Project Name _____ **APCO Order No.** _____

Customer Order No. _____

Original Submittal Date : _____

Prepared by (Print clearly) _____

Revision (Date) _____

All design rights reserved.

Visuline® 2300.1GC Series Semi-Recessed Display



Product Details

Section : Plan View

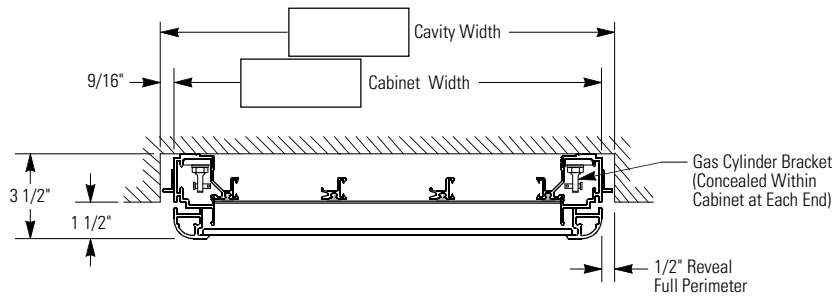

Cut-away Isometric View

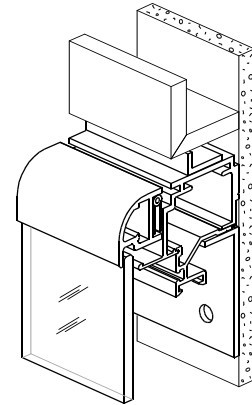

Elevation : Front View

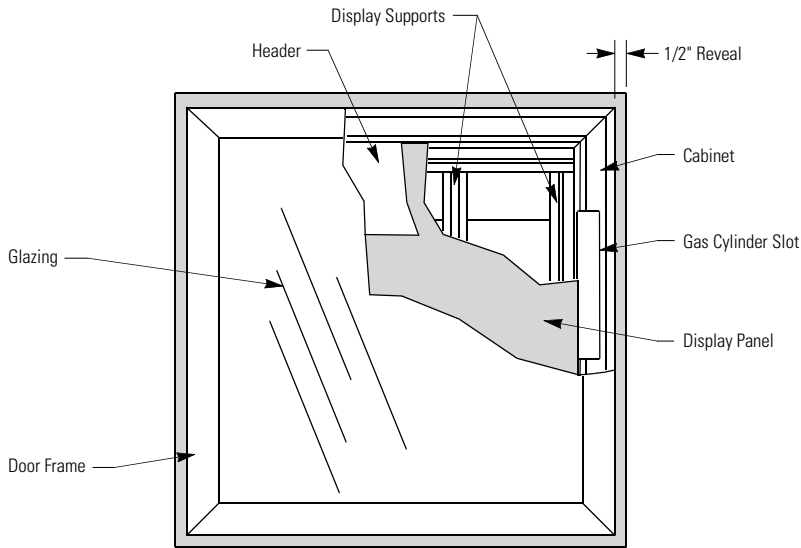

Section : Side View

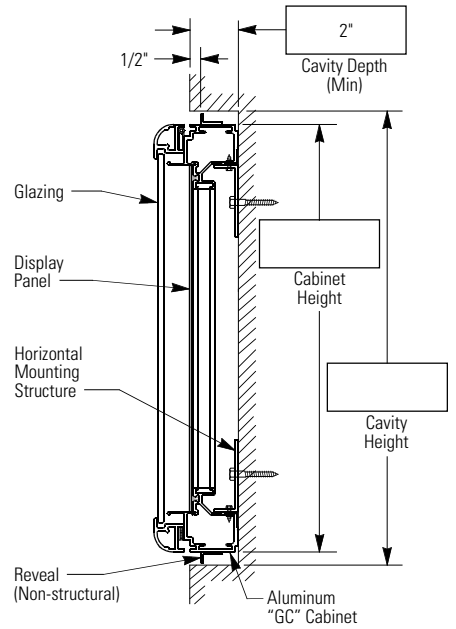

Door Profile Options

All shapes available in aluminum. Brass available in SD & RD only.

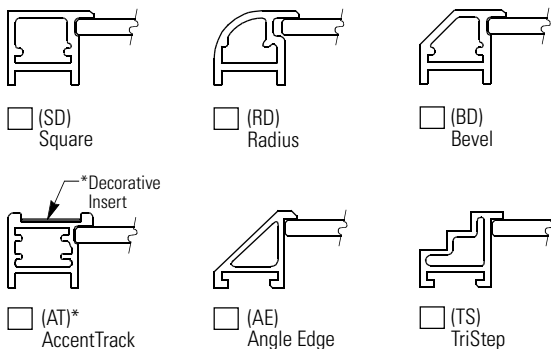

* AccentTrack door accommodates insert materials 1" wide and up to .090" thick, furnished either by APCO or by customer.

Gas Cylinder "Assists"

"GC" Cabinets are specifically designed for heavy, top hinged doors.

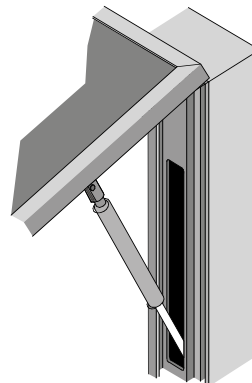

Door Operating Clearance

Front face of door must protrude a minimum 1-1/2" from surrounding surface for door to fully open. Any variation may require factory changes.

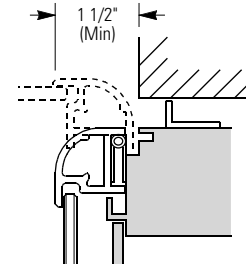

IMPORTANT :
See "Installation / Mounting Details" page to determine Cavity Dimensions.

Visuline® 2300.1GC Series Semi-Recessed Display



Installation / Mounting Details

Section : Plan View

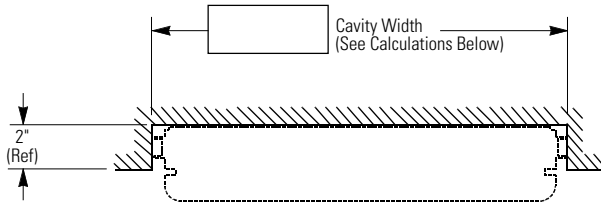

IMPORTANT :

APCO IS NOT RESPONSIBLE FOR CAVITY CONSTRUCTION WHICH VARIES FROM SPECIFICATIONS SHOWN ON THIS PAGE. Wall cavity opening must be precisely constructed in terms of size, squareness and depth. Size calculations and cavity opening tolerances are shown below.

Elevation : Front View

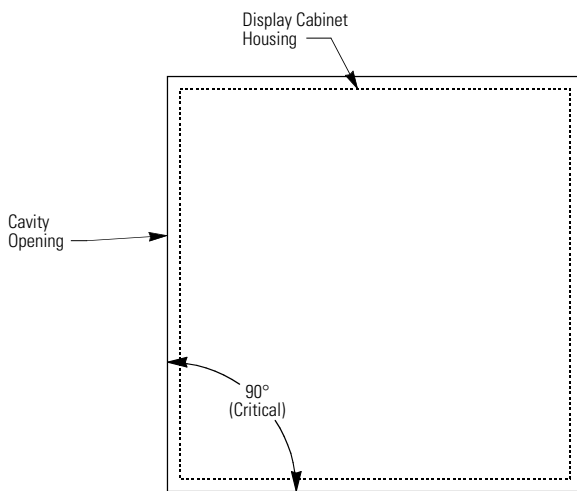

Section : Side View

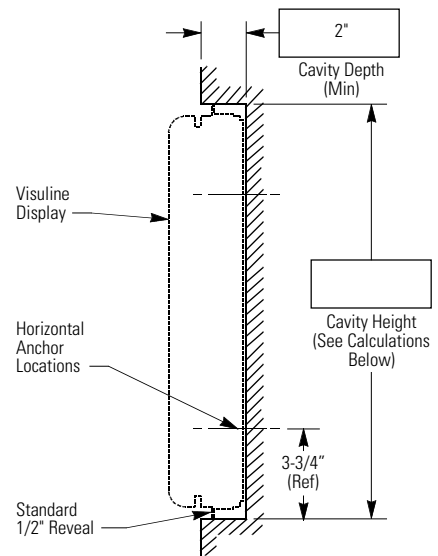

Wall Cavity Size : Standard

1/2" Reveal

A standard 1/2" perimeter Reveal is provided to offset the variance between the cabinet housing and the cavity. To determine cavity opening, add 1-1/8" to both the cabinet's height and width.

$$\boxed{\text{Cabinet Height}} + 1-1/8" = \boxed{\text{Cavity Height}}$$

$$\boxed{\text{Cabinet Width}} + 1-1/8" = \boxed{\text{Cavity Width}}$$

These calculations include a 1/2" Reveal and 1/16" installation clearance around full perimeter.

Overall cavity tolerance is +1/8", minus 0".

