

The exploded view below identifies basic components of the FullView product. Wall attachment (VT) vinyl tape illustrated below.

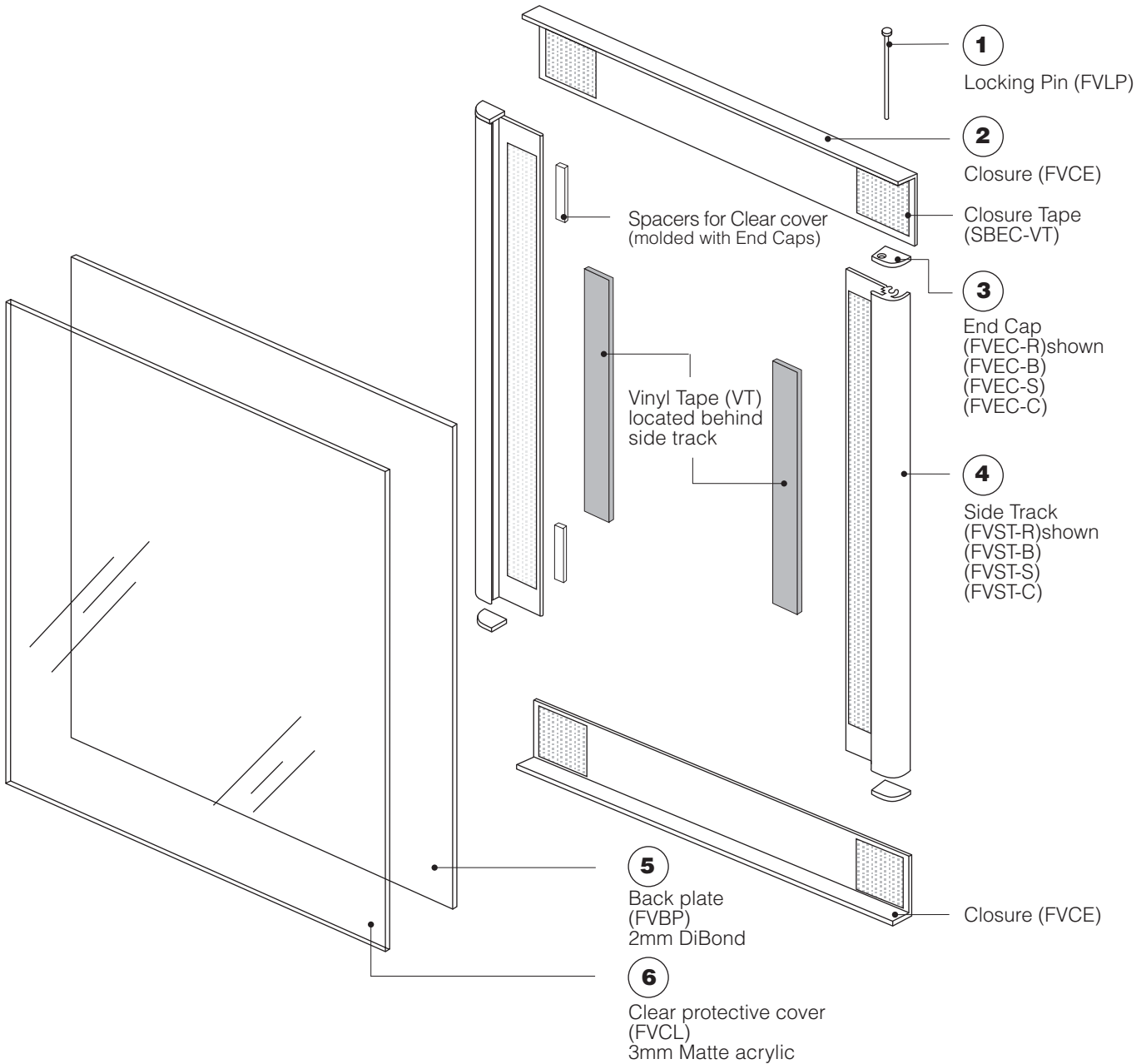

FullView™

Display System

Part Identification

Standard Construction

The exploded view below identifies basic components of the FullView product. Wall attachment methods (MF) mechanical fasteners illustrated below.

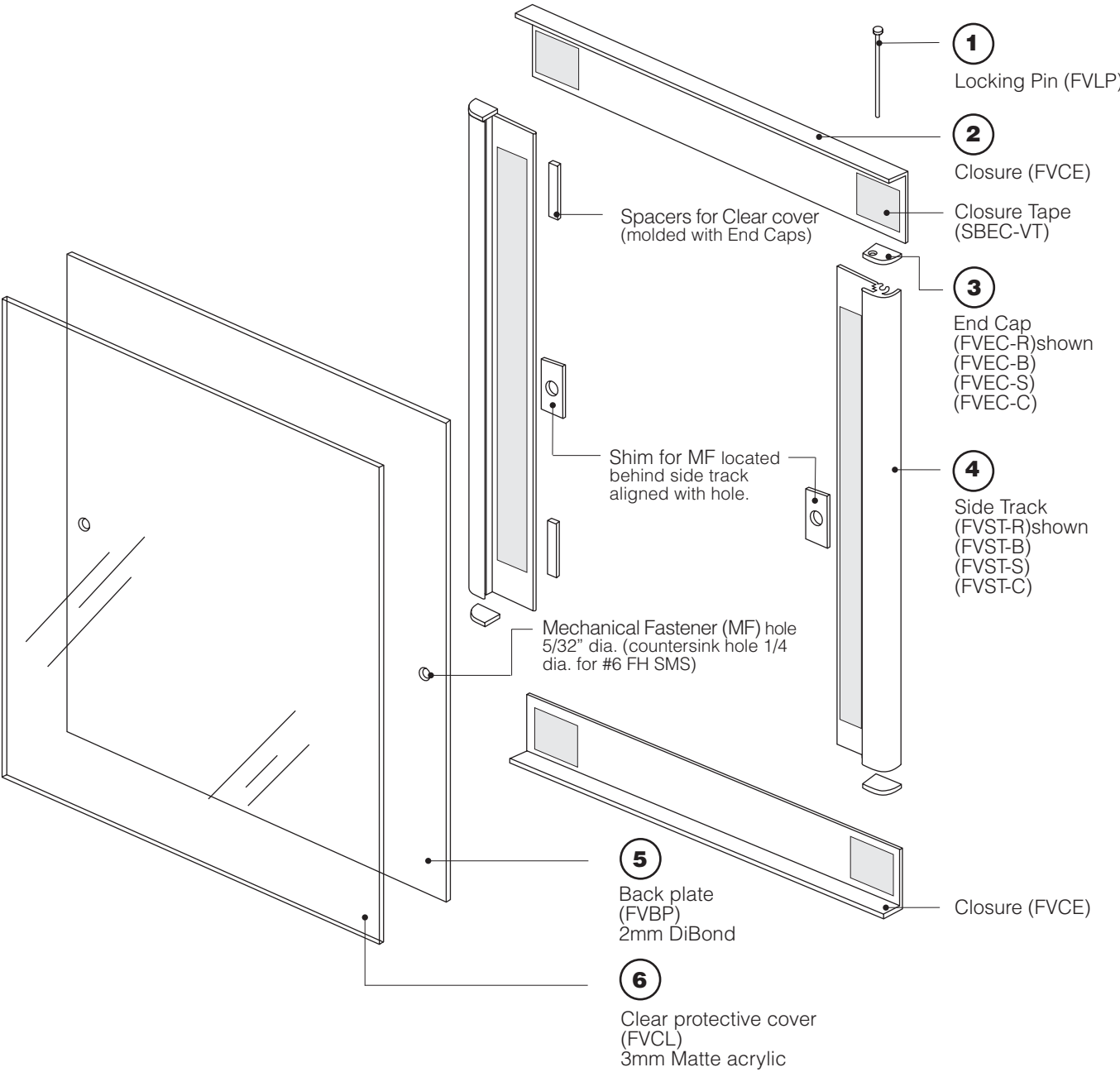

FullView™

Display System

Part Identification

Top Access

The exploded view below identifies basic components of the FullView Top Access product. Wall attachment method is (VT) vinyl tape only.

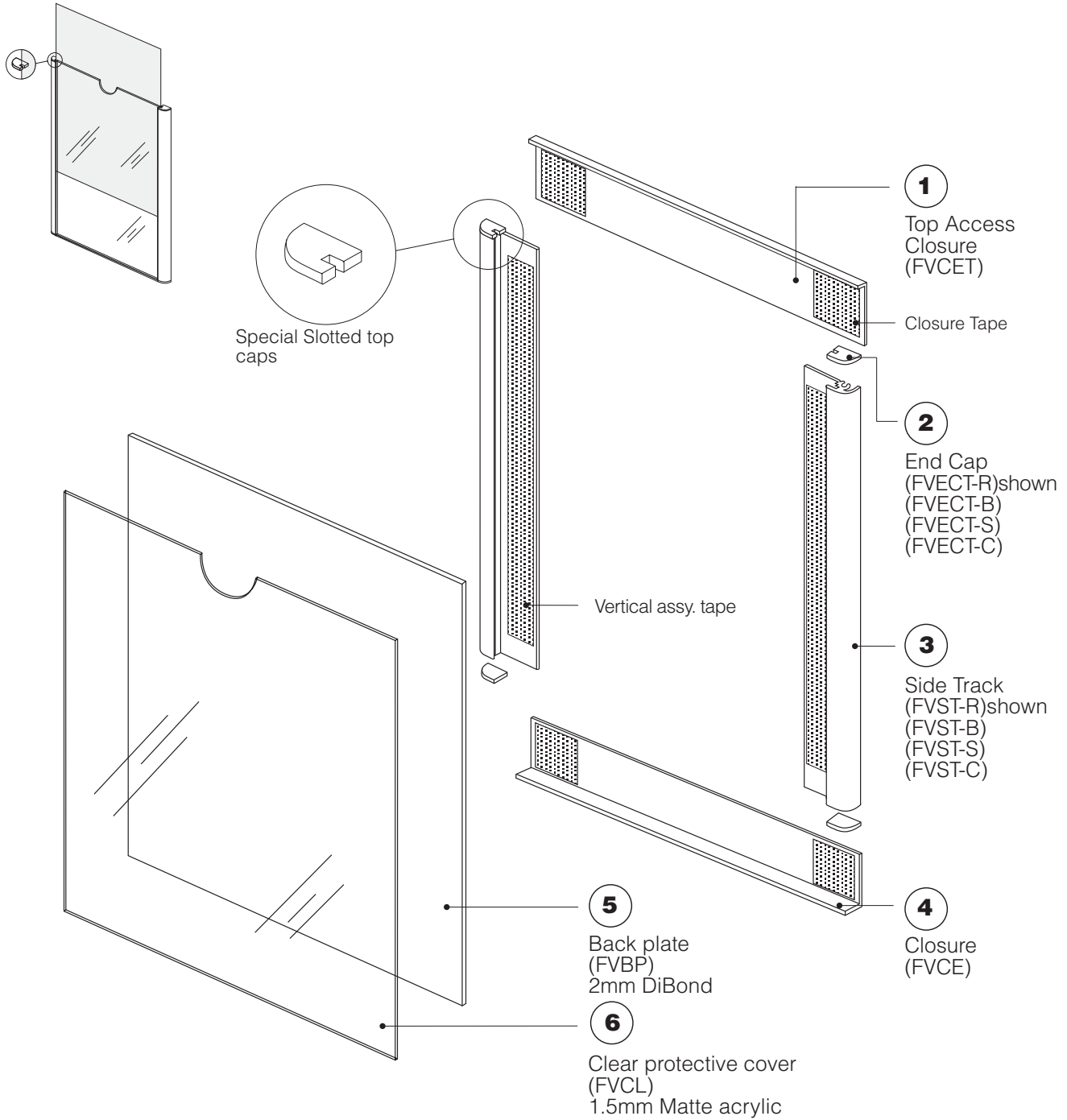

FullView™

Display System

Part Identification

A.D.A. Band Assembly

A.D.A. Band construction must allow Locking Pin access, therefore the band must be placed at the bottom of the assembly. Clear cover and paper access is separated by optional aluminum divider (shown). Typical construction will not include this divider, it must be specified per order.

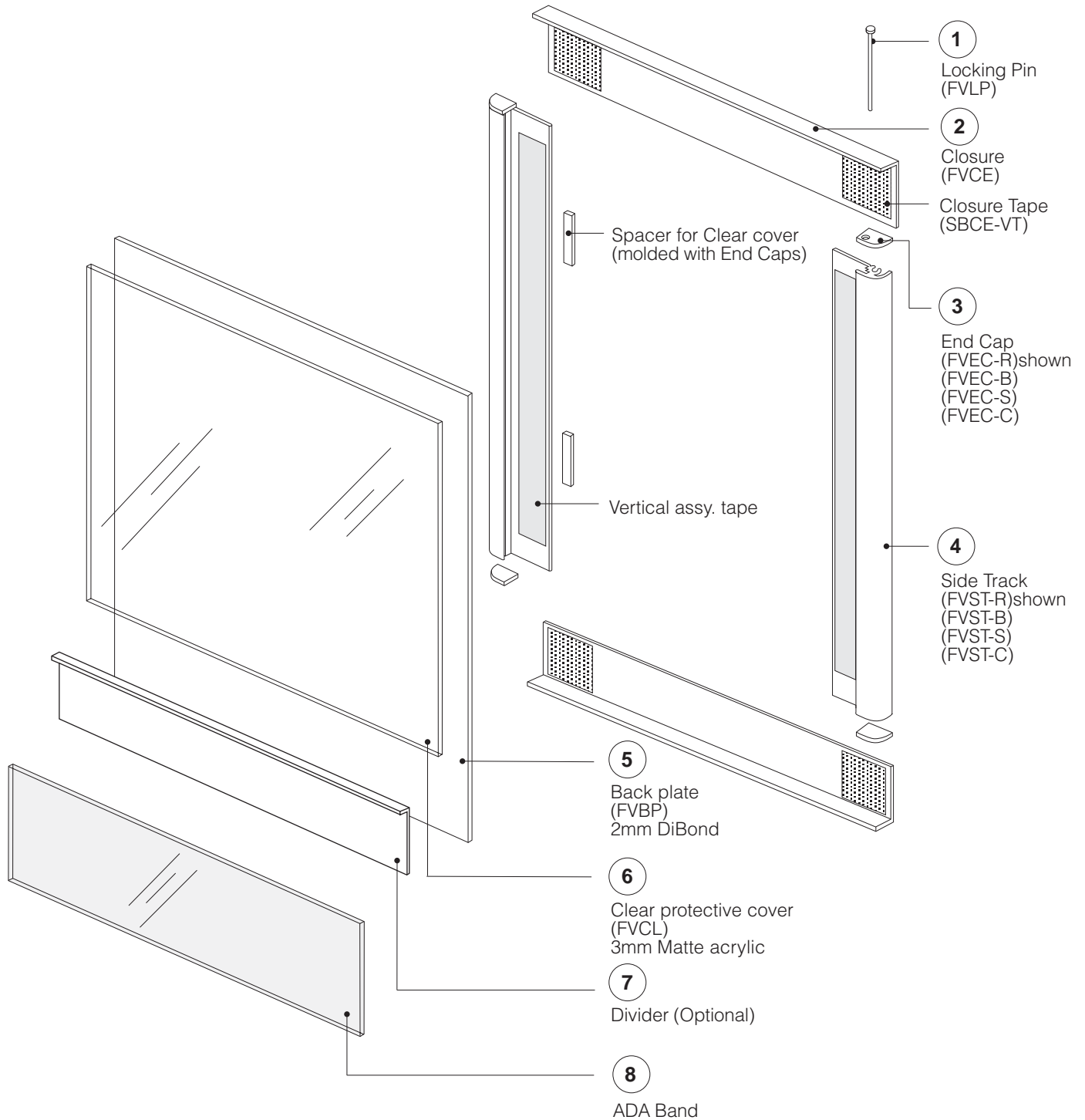

FullView™

Display System

Part Identification

100mm Single Profile Width

The Single Profile FullView will not have a backer as shown in other sizes. The extruded aluminum edge and backer are actually one piece.

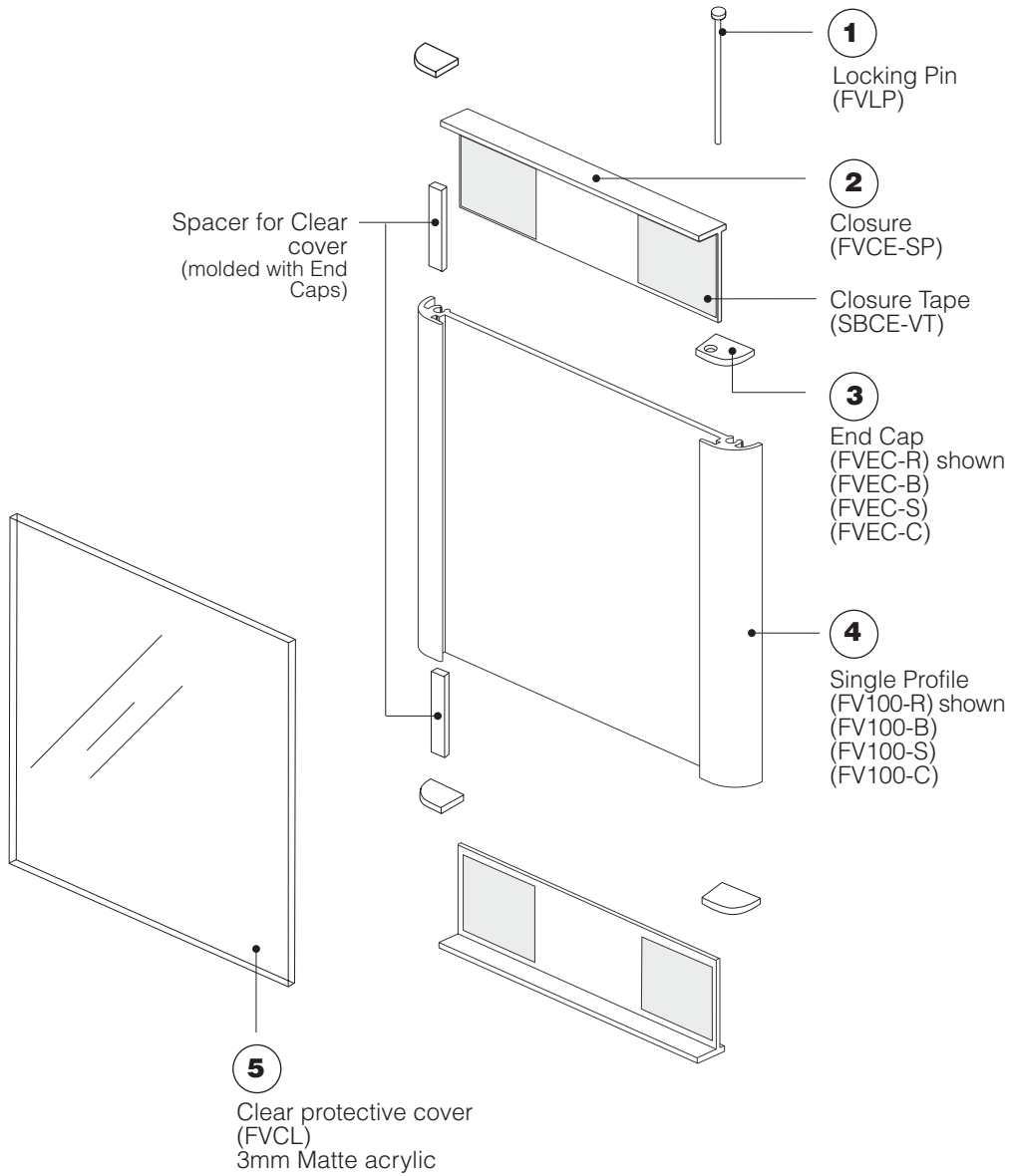

FullView Literature Holders: Standard Wall attachments, Counter Top, Vertical or Inclined, Single or Double sided. Widths: 8 1/2" and 4" for full size and folded literature.

Construction shown for Wall Attachment - Single Sided
Code: FVS12504(V)LH1

