

# PolySign® Single Panel Series

## Non-Illuminated Fiberglass

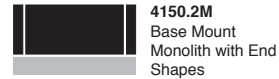

## Assembly & Installation



### Handling

Make sure containers are flat prior to opening, using care not to damage the contents. Depending upon the size of the panel, more than 2 people may be needed for handling. When handling large PolySigns assure that there are an appropriate number of persons to accomplish this before removing the sign from its shipping container. Lay components on a smooth surface. It is preferable to use furniture pads, carpet or even the corrugated board which is found within the shipping crate.

IT IS SUGGESTED THAT YOU NOT REMOVE THE PROTECTIVE WRAPPINGS UNTIL INSTALLATION IS COMPLETE. THIS WILL HELP AVOID DAMAGE TO THE OUTER SURFACES WHILE HANDLING. HOWEVER, IF IT IS NECESSARY TO STORE SIGN OUTSIDE, EXPOSED TO THE ELEMENTS, THIS MATERIAL MUST FIRST BE REMOVED.

The following general information will be helpful, but it is not meant to cover all possible conditions and situations that may occur.

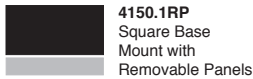

### RP Sign Panel Removal

Prior to installation, one sign panel must be removed for access to mounting hardware. Depending upon the size of the panel, more than 2 people may be needed for handling. To avoid racking and twisting, assure there are an appropriate number of persons to accomplish this *before* removing the sign panel.

1. Loosen and remove the thumb screws located across the lower edge of the sign panel.
2. Rotate lower edge of panel outward then lift it upward to remove. Store panel in a safe place while sign is being installed.

**Important:** In windy conditions, care should be taken not to allow the sign panel to be caught and damaged by an unexpected strong wind.

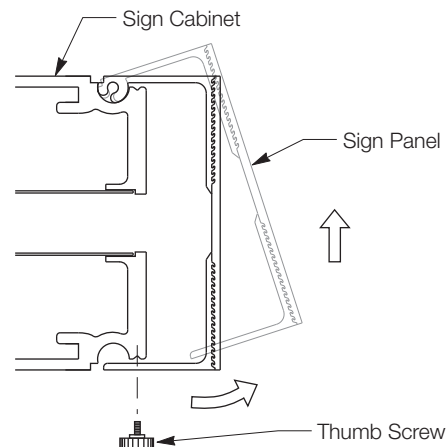

# PolySign® Single Panel Series

## Non-Illuminated Fiberglass



## Assembly & Installation

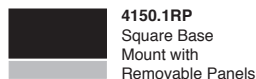

**4150.1RP**  
Square Base  
Mount with  
Removable Panels

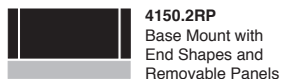

**4150.2RP**  
Base Mount with  
End Shapes and  
Removable Panels

### Installation

At this point, the instructions assume the concrete foundation has been formed and is prepared for sign installation. If foundation has not been formed, refer to "Foundation Construction" later in these instructions.

If the top surface of the foundation is LEVEL and PLUMB, continue to Step 5.

If the top surface of the foundation is NOT level and plumb, it is recommended that the sign skirt first be removed and test-fitted to the concrete base. This step will ensure proper anchor alignment as well as ease the process of leveling the sign.

1. Detach skirt from bottom of cabinet by removing its retaining screws.
2. Locate skirt onto anchors. Identify the area where the studs need leveling and remove skirt.
3. Place a hex nut then a washer onto appropriate studs.
4. Return the skirt back to the foundation and adjust the height of the nuts until the skirt is level. Assure all washers rest evenly against the underside.
5. Lower the Polysign down onto the skirt, aligning anchors bolts with holes provided in the cabinet.
6. Reach inside the bottom cabinet member and secure the sign to the anchor bolts using non-corrosive washers, lockwashers and nuts. Recheck level and adjust if necessary.
7. Replace sign faces. Refer to "Sign Panel Removal" section and reverse Steps 1 and 2.

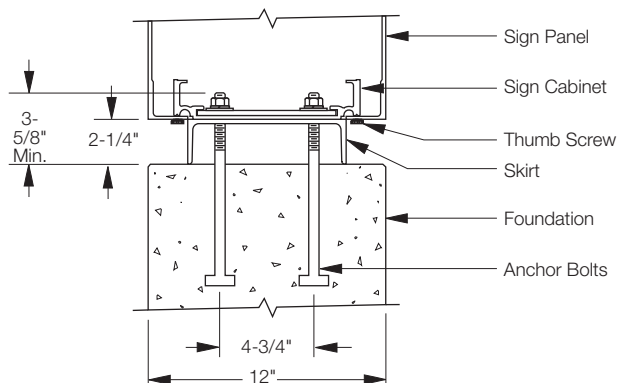
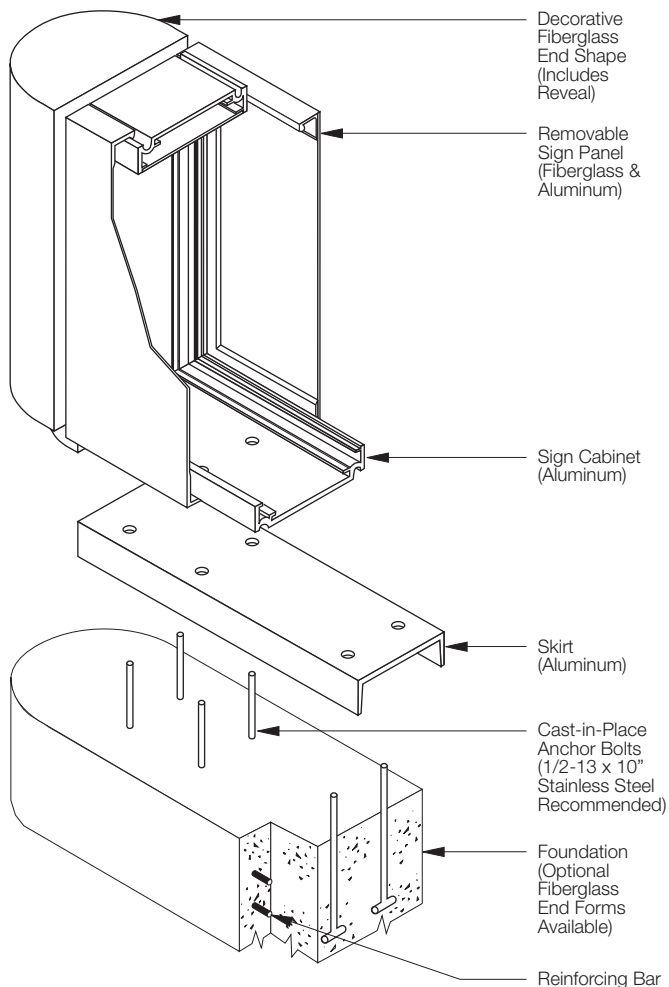

**Anchor Detail**

# PolySign® Single Panel Series

## Non-Illuminated Fiberglass



## Assembly & Installation



**4150.1M**  
Square Base  
Mount Monolith



**4150.2M**  
Base Mount  
Monolith with  
End Shapes

### Sign Preparation

The mounting rack must first be removed from the sign module and secured to the concrete base.

- Using the 3/16" hex wrench provided, remove the button head screws securing the mounting rack to the sign skirt. Pull the rack apart from the sign using care not to damage any surfaces.

### Installation

At this point, the instructions assume the concrete foundation has been formed and is prepared for sign installation. If foundation has not been formed, refer to "Foundation Construction" later in these instructions.

The mounting rack must first be removed from the sign module and secured to the concrete base.

- Using the 3/16" hex wrench provided, remove the button head screws securing the mounting rack to the sign skirt. Pull the rack apart from the sign using care not to damage any surfaces.
- Locate the mounting rack onto the foundation. Level as required and secure using non-corrosive washers, lock washers and nuts.

**Important:** Whether "wedge-type" anchor bolts are used or anchors are precast into foundation, the extended thread length shown must be maintained to properly secure the skirt but not interfere with the PolySign.

- Lower the Polysign down onto the mounting rack and re-align attachment hardware. Use care not to damage any surfaces.
- Reinstall the button head screws.

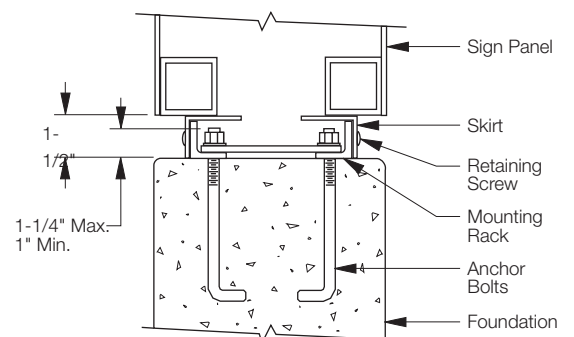
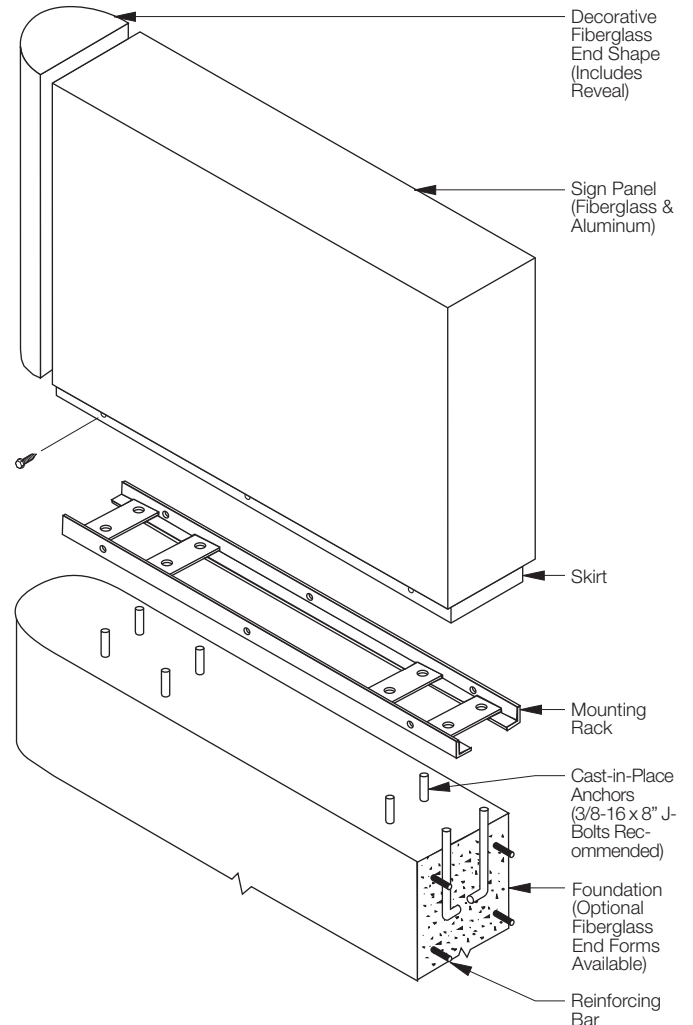

**Anchor Detail**

# PolySign® Single Panel Series

## Non-Illuminated Fiberglass



## Assembly & Installation

### Contractor Notice

Because of widely varying site conditions, installation techniques must be determined on an individual basis. While shop drawings offer suggestions for mounting the PolySign, it should be understood that common sense, caution and care are factors which cannot be built into any product. These factors must be considered by the actual person(s) installing and maintaining the product.

Concrete foundations should be specified by qualified persons, based upon acceptable local codes and geographic practices, such as frost lines, soil conditions, wind load regulations, etc.

APCO accepts no responsibility for foundation design or installation unless performed by APCO. The illustration and details included are intended as suggestions only.

### Foundation Construction

Location of cast-in-place anchors is critical to ensure a smooth sign installation. Each anchor must protrude a predetermined distance above the foundation. The extended thread length shown must be maintained to properly secure the PolySign.

Anchor pattern for standard size products are readily available in pre-printed shop drawing form. APCO offers custom shop drawings for non-typical sizes and/or installation details. Consult factory.

APCO recommends a template be constructed for each sign. Using a 1/4" or 3/8" thick (flat) plywood sheet, accurately layout the anchor bolt pattern and drill 9/16" diameter holes to provide clearance for 1/2" diameter bolts. A rigid template allows anchors to be adjusted to their designed height. This step is critical for a problem-free installation.

**Important:** Before pouring concrete, Assure the top surface of the foundation is LEVEL and PLUMB. Compliance will dictate whether or not the PolySign will be level. Double check pattern layout and make any necessary adjustments.

There are (3) dimensional areas that are critical.

1. Centerline of anchors to edge of concrete base.
2. Centerline of anchors to anchors.
3. Height of anchors above concrete surface.

The illustrations below suggest construction methods for a typical foundation.

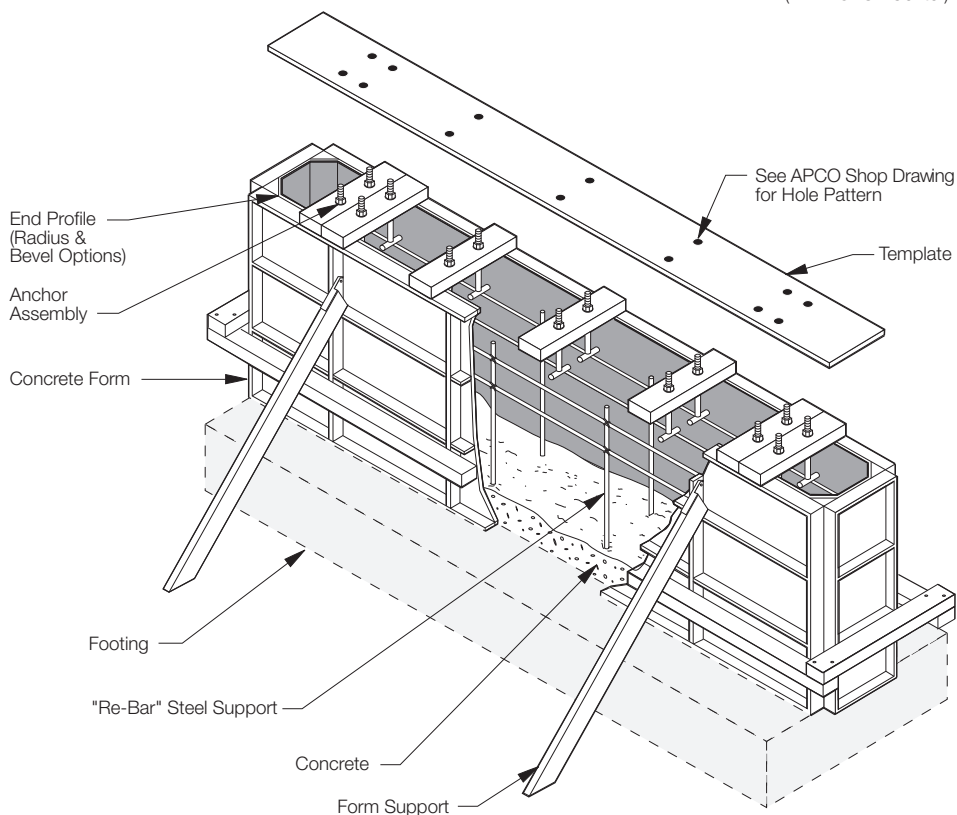
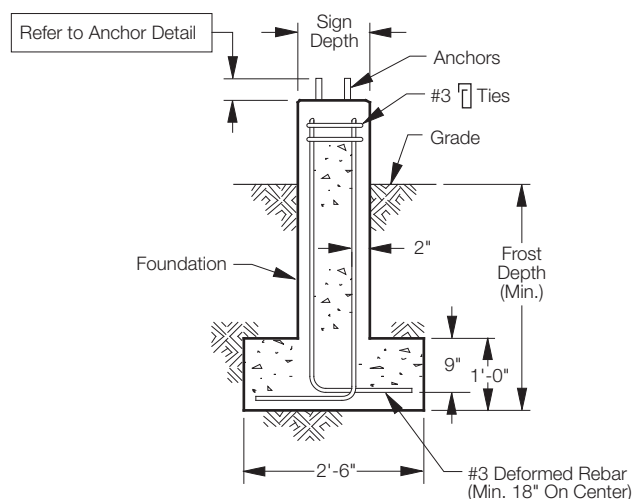

### Additional Information:

Should you encounter any problems whatsoever with installation, call (404) 688-9000 for technical assistance.