

PolySignT Single Panel Series Non-Illuminated Fiberglass



Assembly & Installation



4140.1
Wall Mount
Panel (Monolith)

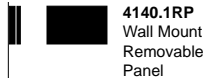

4140.1RP
Wall Mount
Removable
Panel

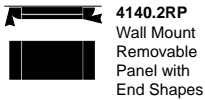

4140.2RP
Wall Mount
Removable
Panel with
End Shapes

Handling

Make sure containers are flat prior to opening, using care not to damage the contents. Depending upon the size of the panel, more than 2 people may be needed for handling. When handling large PolySigns assure that there are an appropriate number of persons to accomplish this before removing the sign from its shipping container. Lay components on a smooth surface. It is preferable to use furniture pads, carpet or even the corrugated board which is found within the shipping crate.

IT IS SUGGESTED THAT YOU NOT REMOVE THE PROTECTIVE WRAPPINGS UNTIL INSTALLATION IS COMPLETE. THIS WILL HELP AVOID DAMAGE TO THE OUTER SURFACES WHILE HANDLING. HOWEVER, IF IT IS NECESSARY TO STORE SIGN OUTSIDE, EXPOSED TO THE ELEMENTS, THIS MATERIAL MUST FIRST BE REMOVED.

The following general information will be helpful, but it is not meant to cover all possible conditions and situations that may occur.



4140.1
Wall Mount
Panel (Monolith)

Wall Mount "Monolith" Panel Installation

The wall mounted "Monolith" PolySign requires no assembly and is ready for installation.

1. Locate top mounting angle against the mounting surface approximately 1/8" lower than desired height of the top of the sign panel. Assure the angle is level. Mark anchor location using holes in angle as a pattern. If necessary, additional holes can be drilled. Attach top mounting angle to mounting surface as required.
2. Place sign panel over top mounting angle. With sign temporarily hanging in position, transfer a line from the bottom sign panel edge to the mounting surface. Masking tape is suggested to avoid marking the surface, however, a chalk line will suffice.
3. Remove sign panel and attach lower mounting angle approximately 1/8" to 3/16" higher than the line marked at the panel bottom. Secure angle to the mounting surface using the appropriate hardware.

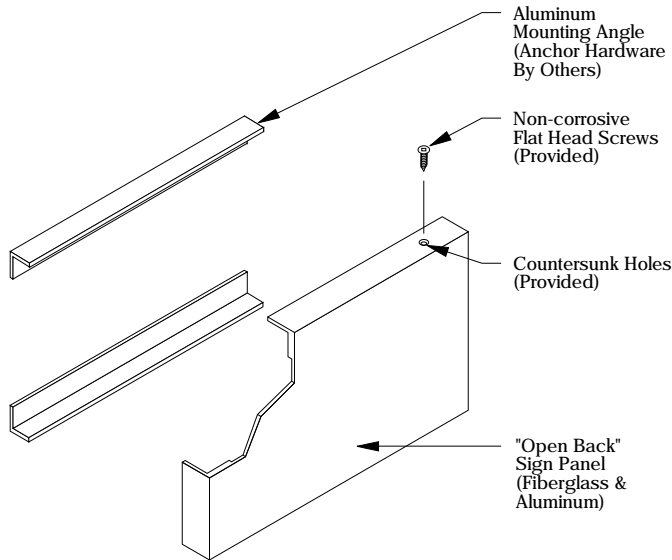

Fastener Suggestions

Hardware for attaching the wall mounted version of PolySign is not included and should be specified by qualified persons based upon local codes, regulations, etc. Consideration must be given to conditions unique to each mounting structure.

APCO accepts no responsibility for installation unless performed by APCO. The illustration and details included are intended as suggestions only.

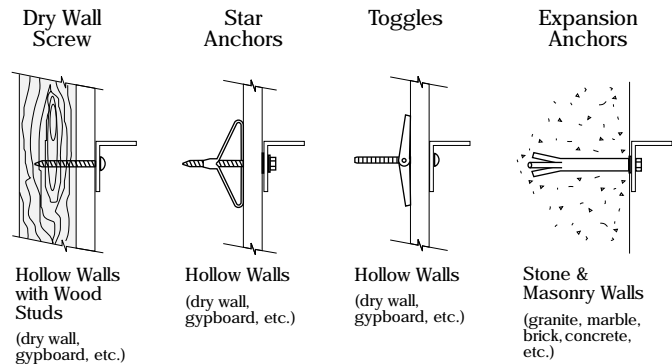

PolySignT Single Panel Series

Non-Illuminated Fiberglass



Assembly & Installation

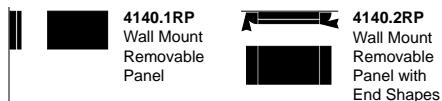

RP Sign Panel Removal

Prior to installation, the sign face must be removed for access to assembly or mounting hardware. Depending upon the size of the panel, more than 2 people may be needed for handling. To avoid racking and twisting, assure there are an appropriate number of persons to accomplish this *before* removing the sign face.

1. Loosen and remove the thumb screws located across the lower edge of the sign face.
2. Rotate lower edge of panel outward then lift sign face upward to remove. Store panel in a safe place while sign is being prepared for installation.
3. Remove all fluorescent lamps and store them in a safe place.

Important: In windy conditions, care should be taken not to allow the sign panel to be caught and damaged by an unexpected strong wind.

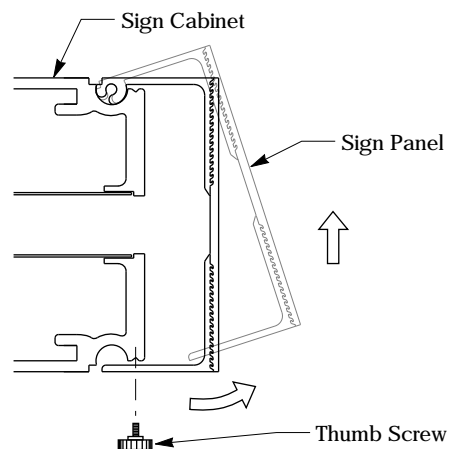

Wall Mount RP Installation

Fiberglass end shapes (4140.2RP series) are decorative and non-structural. Do not use the end shapes for lifting.

1. Temporarily locate the PolySign into its installed position and mark the surface using the mounting holes provided as a template. Remove the sign.
2. Depending on type of fastener chosen, a pilot hole may be required at this time or anchor/anchor receptacles may need to be set.
3. Reposition sign and anchor into place.
4. Reinstall sign face.

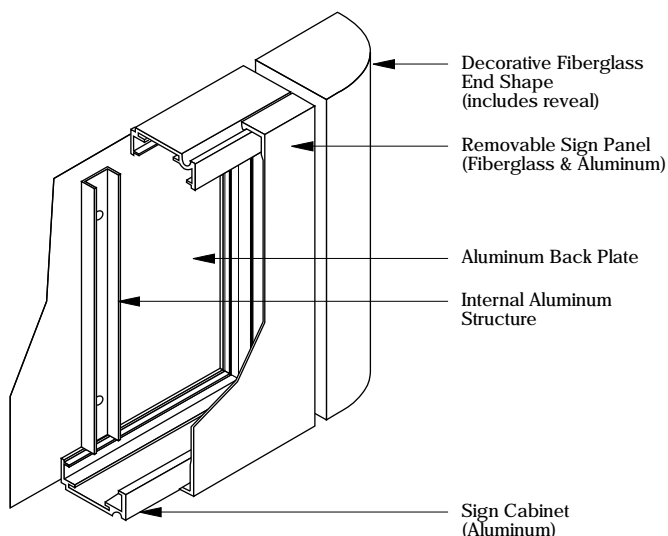

Contractor Notice

Because of widely varying site conditions, installation techniques must be determined on an individual basis. While shop drawings may offer suggestions for mounting the PolySign, it should be understood that common sense, caution and care are factors which cannot be built into any product. These factors must be considered by the actual person(s) installing the product.

Additional Information:

Should you encounter any problems whatsoever with installation, call (404) 688-9000 for technical assistance.