

Visulite® 2210.2LP Series

Full Recessed Directory



SUBMITTED FOR APPROVAL

This product is scheduled for shipment the week of :

Date _____

Production cannot begin until one (1) copy of these drawings is returned with your signature of approval by :

Date _____, otherwise rescheduling will be necessary. Drawing revisions may also require rescheduling.

Retain _____ Set(s)

Return _____ Set(s)

Customer Approval Required *(Check appropriate box)*

Purchaser _____

By (Print name & title clearly) _____

Signature _____ Date _____

Approved for Production

Approved as noted

Not approved
Resubmit with changes
Product subject to rescheduling

FOR REFERENCE ONLY *(Customer Waives Approval)*

Production Has Begun

This product is scheduled for shipment the week of :

Date _____

It is understood that customer, in waiving formal approval procedure, assumes full responsibility for the specifications, dimensions and details included herein.

APCO Use

Project Name _____ **APCO Order No.** _____

Customer Order No. _____

Original Submittal Date : _____

Prepared by (Print clearly) _____

Revision (Date) _____

All design rights reserved.

Visulite® 2210.2LP Series Full Recessed Directory



Product Details

Section : Plan View

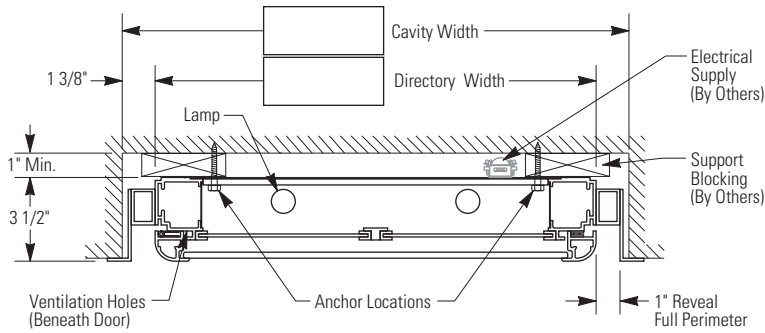

Cut-away Isometric View

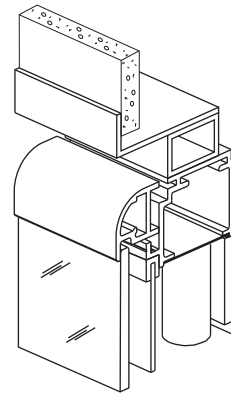

Elevation : Front View

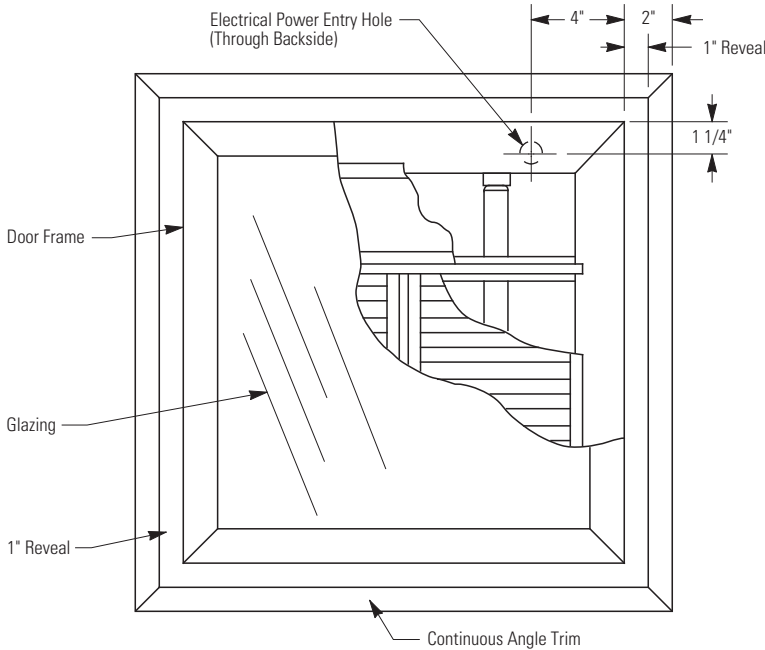

Section : Side View

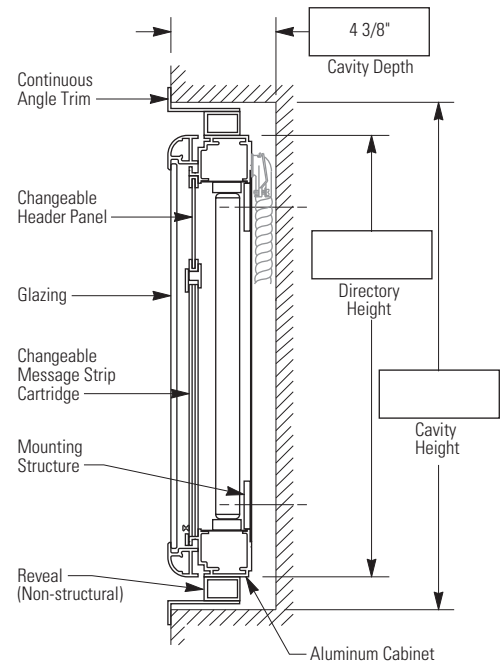

Door Profile Options

All shapes available in aluminum.

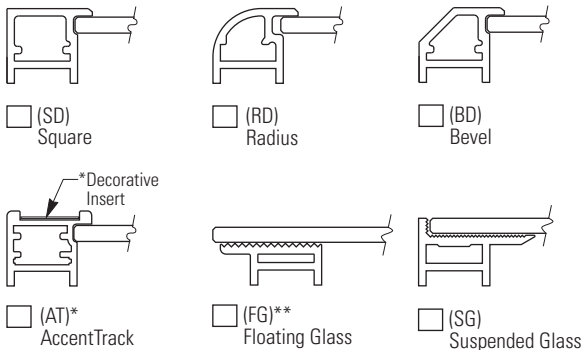

Door Operating Clearance

A 1" wide Reveal (tube) is attached to the cabinet at a 1-1/2" depth to maintain proper door operation. A decorative, non-structural trim is then attached to the tube.

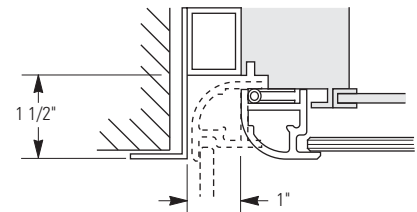

* AccentTrack door accommodates insert materials 1" wide and up to .090" thick, furnished either by APCO or by customer.

** Specifications for Floating Glass Door Profile are illustrated on separate Shop Drawing 2210.2LP Full Recessed - Floating Glass.

IMPORTANT :
See "Installation / Mounting Details" page to determine Cavity Dimensions.

Visulite® 2210.2LP Series Full Recessed Directory



Specifications

Product

Size: H.* _____ W. _____ D. 3-1/2"
Estimated Weight _____

Cavity Opening Size

(See Note 1)

- Existing Cavity
 To Be Constructed

Size: H. _____ W. _____ D. _____

Door Frame Shape

- Square AccentTrack
 Radius
 Bevel
 Suspended Glass

Use separate Shop Drawing for Floating Glass Door option

Configuration

- A With Standard 4" Header
 B Without Header
 C Full Size Display (See Note 2)
 D Combination
(Include all specifications)

1/2" Message Strip / Qty.
 NS-50; 1/2" x 7" / _____
 NS-35; 1/2" x 3-1/2" † / _____
No. of Columns _____

1" Message Strip / Qty.
 NS-100; 1" x 11" / _____
 NS-55; 1" x 5-1/2" †† / _____
No. of Columns _____

Note 1

Wall cavity size is determined by adding cabinet housing, surrounding reveal, trim and installation clearance. Trim styles and cavity opening calculations for each are illustrated on "Installation / Mounting Details" page.

Note 2

Dimensions for determining illuminated area are calculated by subtracting 4-3/8" from both the directory's standard height* and width.

Height _____ - 4-3/8" = _____ Width _____ - 4-3/8" = _____
(Illuminated Area) (Illuminated Area)

Note 3

Composite glazing (i.e. Acrylic, Lexan, etc.) is not used. These materials are not as strong as tempered glass, they are more vulnerable to scratches and expansion enhances imperfections in their natural uneven and wavy surfaces.

† NS35 copy length is 2-1/4". Copy height is limited to 1/8" (approximately 23 characters.)

†† NS55 copy length is 4-3/16". Copy height should be specified to fit within this area.

* Standard directory heights are based on available lamp lengths.

Hinge Location

- Left
 Top
(Opens approx. 60°, 75° or 90°, depending on door size & shape)
 Other _____

Door Locking Device

- 3M "Dual Lock" Fastener (Included)
 Conventional Keyed Cam Lock

Glazing

- Tempered Safety Glass with Graylite #14 Tint (See Note 3)

Continuous Angle / Trim

(See Note 1)

- 1" Wide Angle (Standard)
 1/8" Wide "Flat Bar" Trim
 Omit Angle / Trim (1" Reveal Remains)
 Other _____

Electrical

Voltage

- 120V, 60Hz (Standard)
 277V, 60Hz

Amperage _____

Power Entry

- Upper Right Corner Thru Backside (Standard)
 Other _____
(Show on "Product Details" page)

Lamps

Type _____
Quantity _____

Finishes

Door

- Natural Satin Anodized
 313 Dark Bronze Anodized
 315 Black Anodized
 Other _____

Housing

- Natural Anodized
 313 Dark Bronze Anodized
 315 Black Anodized
 Other _____

Reveal

- Natural Satin Anodized
 313 Dark Bronze Anodized
 315 Black Anodized
 Other _____

Continuous Angle / Trim

(See Note 1)

- Natural Satin Anodized
 313 Dark Bronze Anodized
 315 Black Anodized
 Other _____

Special Comments

Visulite® 2210.2LP Series Full Recessed Directory



Installation / Mounting Details

Section : Plan View

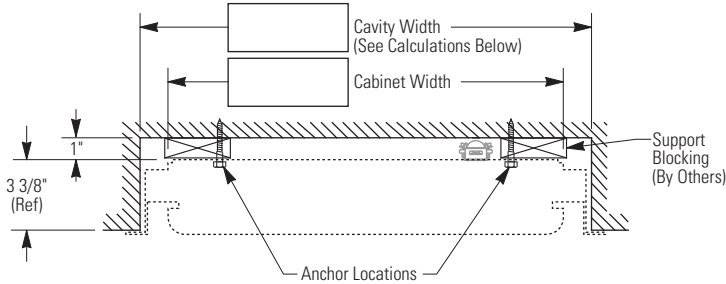

IMPORTANT :
APCO IS NOT RESPONSIBLE FOR CAVITY CONSTRUCTION WHICH VARIES FROM SPECIFICATIONS SHOWN ON THIS PAGE. Wall cavity opening must be precisely constructed in terms of size, squareness and depth. Size calculations and cavity opening tolerances are shown below for each trim style.

Elevation : Front View

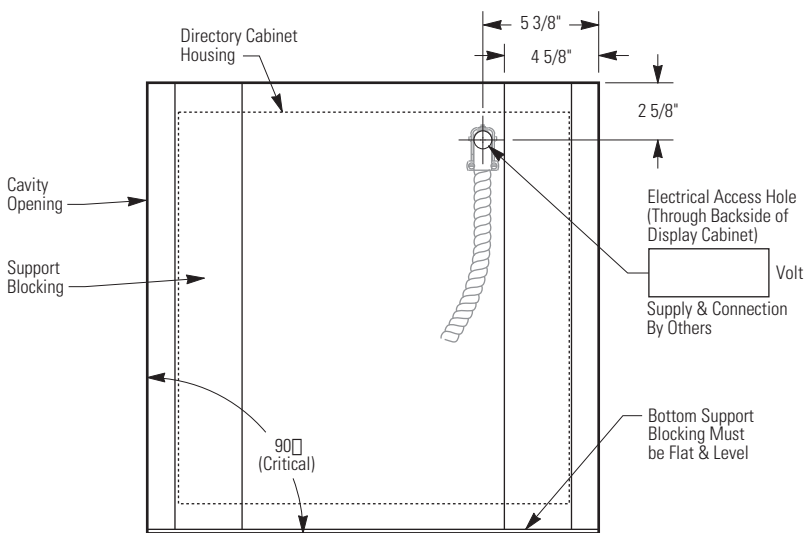

Section : Side View

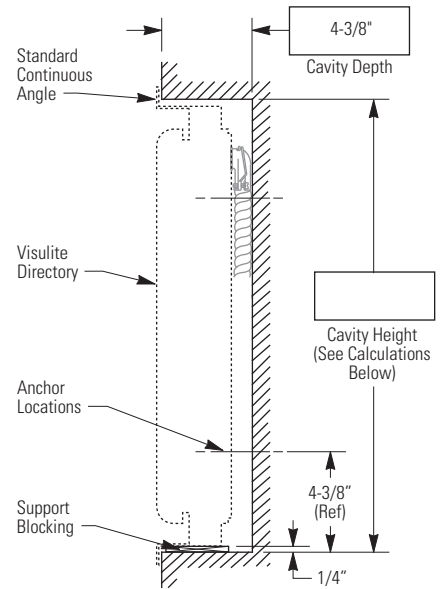

Cavity Size : Standard

Continuous Angle

The Continuous Angle is recommended to conceal rough cut openings while allowing for inconsistencies in cavity size. It also helps to avoid obstruction of the reveal area which is required for proper door operation. To determine cavity opening, add 2-3/4" to both the cabinet's height and width.

$$\boxed{\text{Cabinet Height}} + 2\text{-}3/4" = \boxed{\text{Cavity Height}}$$

$$\boxed{\text{Cabinet Width}} + 2\text{-}3/4" = \boxed{\text{Cavity Width}}$$

These calculations include a 1" Reveal, 1/8" thick Continuous Angle and 1/2" total installation clearance.

Overall cavity tolerance is +/- 1/8".

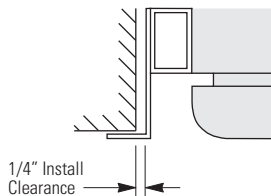

Cavity Size : Optional

"Flat Bar" Trim

A 1/8" wide "Flat Bar" can be substituted when the 1" wide Continuous Angle is not desired. To determine cavity opening, add 2-3/8" to both the cabinet's height and width.

$$\boxed{\text{Cabinet Height}} + 2\text{-}3/8" = \boxed{\text{Cavity Height}}$$

$$\boxed{\text{Cabinet Width}} + 2\text{-}3/8" = \boxed{\text{Cavity Width}}$$

These calculations include a 1" Reveal, 1/8" thick Flat Bar and 1/8" total installation clearance.

Overall cavity tolerance is +1/8", minus 0".

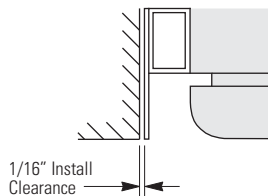

Cavity Size : Optional

Angle / Trim Omitted

When cavity space is a factor, the surrounding trim can be eliminated to obtain the largest directory/cavity combination. The 1" reveal remains to maintain proper door operation. To determine cavity opening, add 2-1/8" to both the cabinet's height and width.

$$\boxed{\text{Cabinet Height}} + 2\text{-}1/8" = \boxed{\text{Cavity Height}}$$

$$\boxed{\text{Cabinet Width}} + 2\text{-}1/8" = \boxed{\text{Cavity Width}}$$

These calculations include a 1" Reveal and 1/8" total installation clearance.

Overall cavity tolerance is +1/8", minus 0".

